

# GOLF NETS

## FOLDAWAY DELUXE

Golf Aids. +44(0)1179539353. Fax +44(0)1179231251 e-mailhelpdesk@golfaims.co.uk www.golfaims.co.uk

### PARTS LIST

- A Baffle Net**
- A1 Velcro Fixings**
- B Surround Net**
- B1 Blue pockets for top arms**
- B2 Blue eyelets for top bar**
- C Top Arms**
- D1 Top Bar Male**
- D2 Top Bar Female**
- E1 Front Leg Top half**
- E2 Front Leg Lower half**
- F1 Rear leg Top half**
- F2 Rear Leg Lower half**
- G1 Back Horizontal Brace Male**
- G2 Back horizontal brace Female**
- H Top Arm Support**
- J Ring Clamps**
- K Rear Leg support arm**
- L Bolt and Wingnut for Support Arms**
- M T-Clamps**
- N Fixings for ground Pegs**

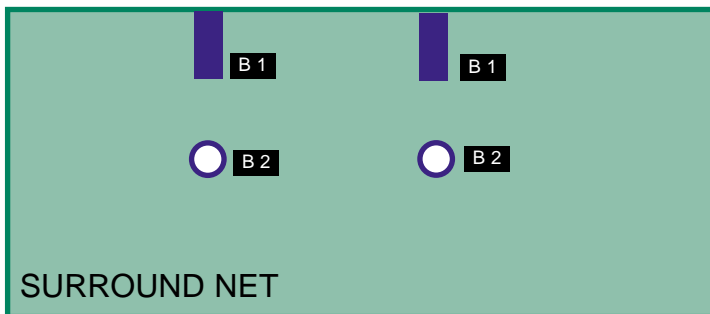
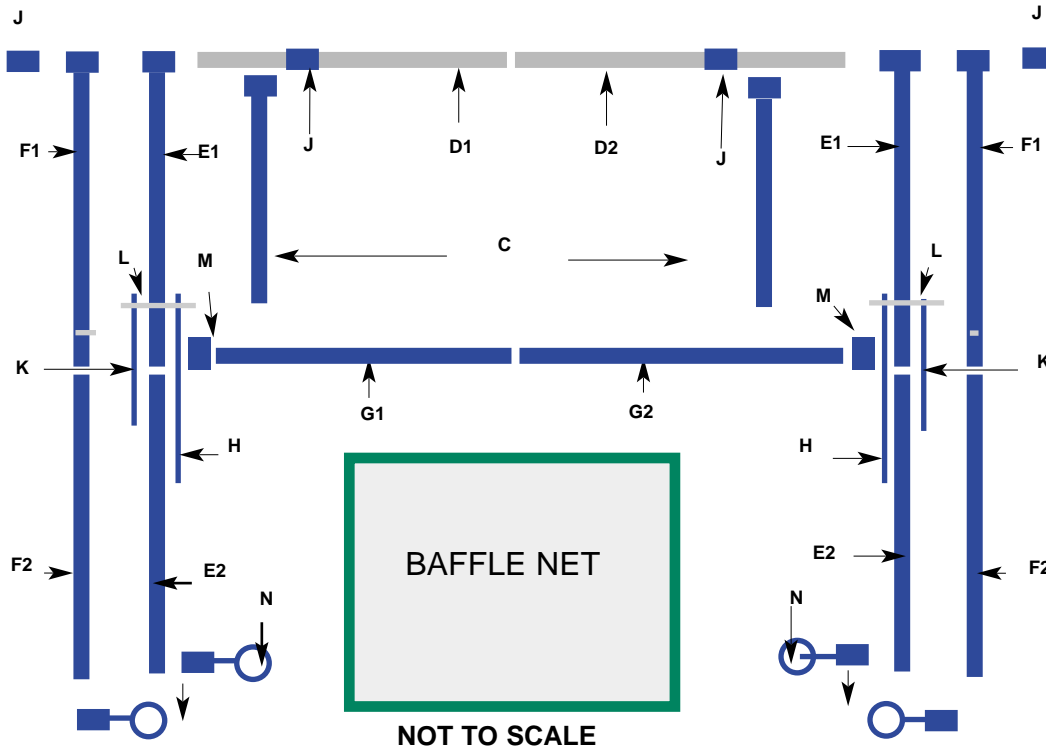

## ASSEMBLY INSTRUCTIONS

1 Lay out all parts as parts diagram above with the surround net underneath. Leave the baffle to one side as that is attached later.

2 \*Screw together top bar (D) (gray bars) and the two front legs. *(The bottom halves of all the legs are identical. The top of the front legs differ from the top of the back legs as the hole for the support arm bolt is nearer the top on the front legs. The rear bracing bar is made up of the two longer halves)*

3 Remove the two outside ring-clamps (J) and thread the top bar (D) through the two blue eyelets in the surround net. (B2)

4 Then slot the two top arms (C) (one either end) followed by the complete front legs (E) and the two top halves of the rear legs (F1). Then slot the remaining two ring-clamps (J) at each end of the top bar and tighten grub screw. Fig.1

5 Using bolt and wing nut (L) bolt top arm support (H) and rear leg support to hole provided in front leg.

6 Then lift one end of the top bar and

secure top arm support into hole in top arm. Complete both sides.

7 Repeat the same process for the rear legs

8 Lift top end of rear leg (F2) and attach rear leg support arm. Then complete the other side.

9 Attach T-clamps (M) to ends of rear top legs. Then attach Back horizontal brace to these T-clamps and tighten all grub screws.

10 Screw in the lower halves (F2) of the rear legs.

11 Lift frame into position by catching hold of back bracing bar, lift and pull towards you.

12 Attach fixing for ground pegs to base of all 4 legs.

13 Attach surround net selvage to fixings for ground pegs (N) before pegging into ground. (pegs not included)

14 Roll up surplus net to make a cushion to stop low hit balls.

15 Attach baffle using velcro strip (A1)

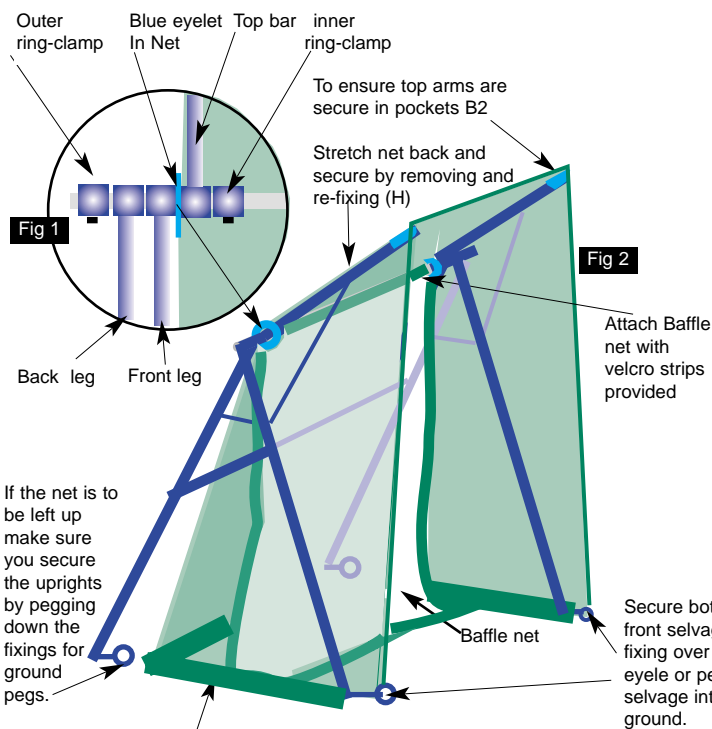

**GOLF BALLS CAN BE DANGEROUS AND USERS ARE ADVISED TO KEEP PETS AND CHILDREN AWAY FROM THE PRACTICE AREA DURING NET PRACTICE. WHEN NOT IN USE IT IS BEST TO POSITION THE NET FACE DOWN USING REAR BRACING BAR. DO NOT LEAVE BAFFLE UP DURING WINDY CONDITIONS AS IT MAY ACT AS A SAIL AND DAMAGE THE NET**

\* It is advisable to smooth a little oil or grease over all the screw threads prior to fixing.